

Professional Series

Key Features:

- ▶ 45 Hz to 18 kHz Frequency Range
- ▶ High Sensitivity, 96 dB SPL, 1 W, 1 m (3.3 ft)
- ▶ High Power Handling Capability: 250 watts continuous pink noise
- ▶ Convenient mounting design uses JBL QuickMount™, Omnimount® or APC Multimount brackets
- ▶ Special cabinet shape incorporates 20° angled front baffle
- ▶ SMPTE/ISO2969 Curve X high frequency de-emphasis
- ▶ Lightweight, rigid molded enclosure
- ▶ Input terminals located on top of cabinet for quick access
- ▶ Uniform horizontal and vertical coverage
- ▶ Approved by Lucasfilm, Ltd. for THX® installations

The 8340A Cinema Surround Speaker offers very high power handling, high sensitivity, and extended bass response in a very compact enclosure. The two-way 8340A's proven reliability and performance features have positioned it as the industry standard for the extended dynamic range required by digital sound formats.

The 8340A features a high power, long-throw 250 mm (10 in) low frequency driver for smooth, extended bass response. The high frequency section combines a 25 mm (1 in) titanium diaphragm compression driver with a constant coverage horn for very high output capability and wide, even high frequency coverage. The 250 watt continuous power rating (1000 watt peak) provides extended dynamic range required for digital soundtracks with absolute reliability.

Its modern, molded black textured enclosure with black grille enhances any decor.

JBL's QuickMount bracket allows one person to quickly and simply mount the very lightweight enclosure on a previously installed bracket half.

Built to traditional JBL quality standards, the 8340A will stand up to long-term use under adverse conditions while delivering excellent performance.

Omnimount is a registered trademark of Omnimount Systems.



Specifications:

System:

Frequency Range (-10 dB):	45 Hz - 18 kHz
Frequency Response (±3 dB):	75 Hz - 16 kHz
Power Rating ¹ :	250 watts continuous pink noise, 1000 watts peak
Sensitivity ² :	96 dB SPL, 1W @ 1m (3.3 ft)
Nominal Impedance:	8 ohms
Hor. Coverage Angle (-6 dB):	100° averaged 400 Hz to 12 kHz
Vert. Coverage Angle (-6 dB):	80° averaged 400 Hz to 12 kHz
Directivity Factor (Q):	7 averaged 400 Hz to 12 kHz
Directivity Index (DI):	8.4 dB averaged 400 Hz to 12 kHz
Crossover Frequency:	2.2 kHz
High Frequency Contour:	ISO2969 Curve X surround contour
Polarity:	EIA (Positive voltage to RED terminal gives forward cone motion)

Low Frequency Transducer:

Nominal Diameter: 250 mm (10 in)

High Frequency Transducer:

Nominal Diameter: 25 mm (1 in)

Physical:

Downward Firing Angle:	Nominal 20° when mounted flush on back panel
Enclosure Material:	Textured Black H.I.P.S. Plastic
Grille Color:	Black
Input Connectors:	5-way binding posts
Dimensions (H x W x D):	457 mm x 457 mm x 260 mm (18 in x 18 in x 10.25 in)
Net Weight:	8.6 kg (19 lb)

¹Rating based on test signal of IEC filtered random noise with a peak-to-average ratio of 6 dB, two hours duration.
²Sensitivity is based on a swept 500 Hz to 2.5 kHz test signal for an input of 2.83V @ 8 ohms.

JBL continually engages in research related to product improvement. Some materials, production methods and design refinements are introduced into existing products without notice as a routine expression of that philosophy. For this reason, any current JBL product may differ in some respect from its published description, but will always equal or exceed the original design specifications unless otherwise stated.

▶ 8340A High Power Cinema Surround Speaker for Digital Applications

Frequency Response in half-space (2π , solid line) and full-space (4π , dotted line), and Input Impedance

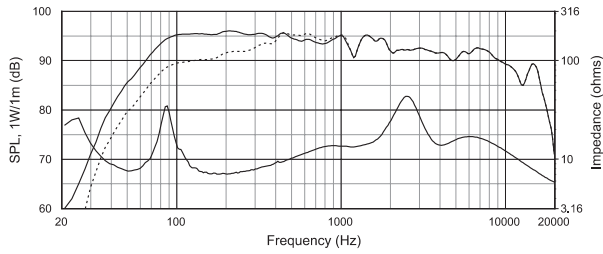

Beamwidth vs. Frequency

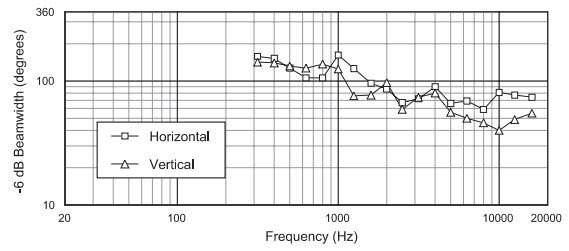

Horizontal Off-Axis Frequency Response

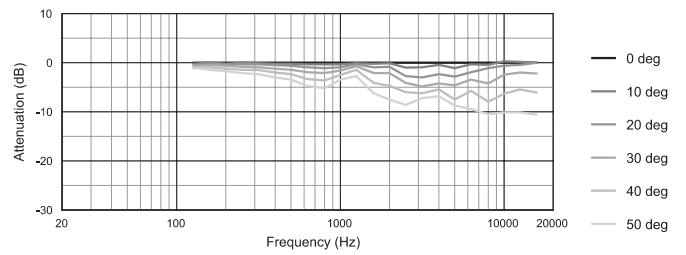

Vertical Off-Axis Frequency Response (down)

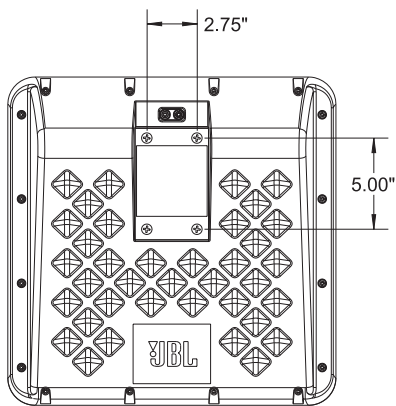
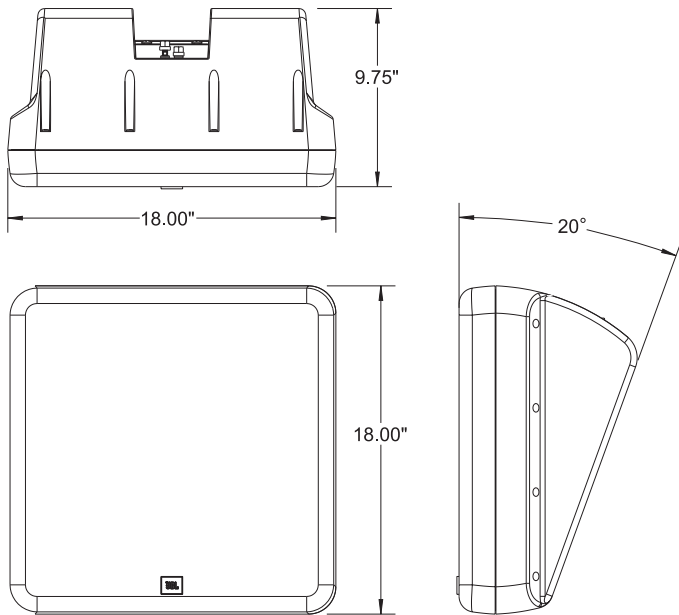
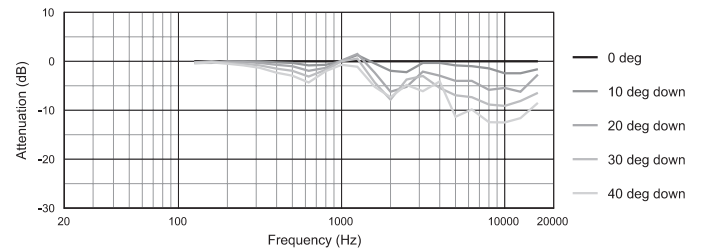

JBL Professional
8500 Balboa Boulevard, P.O. Box 2200
Northridge, California 91329 U.S.A.

■ A Harman International Company

SS 8340A
CRP 15M
2/99